

Cervoz Industrial Memory Card

CompactFlash

Momentum Series (MLC)

M141 Family

Product Datasheet



Date: 2022.12.30

Revision: 1.1

File: Cervoz_Industrial_Memory_Card_CompactFlash_M141_Datasheet_Rev1.1



Revision History

Date	Revision	Description
2021.10.12	1.0	First Released
2022.12.30	1.1	MTBF Updated



Table of Contents

1. Product Overview.....	4
1.1 Introduction.....	4
1.2 Feature.....	4
1.3 Product Appearance & Models.....	5
2. Product Specifications.....	6
2.1 General Specifications.....	6
2.2 Electronic Specifications.....	7
2.2.1 Block Diagram.....	7
2.2.2 Pin Assignment.....	8~9
2.3 Environmental Specifications.....	10
2.4 Mechanical Specifications.....	10
3. Supported Command.....	11
3.1 Identify Drive Information.....	11~12
4. Part No. Decoder.....	13
4.1 Part No. Decoder.....	13~14

1. Product Overview

1.1 Introduction

Cervoz Industrial CompactFlash Card M141 family is a high capacity Solid State Flash Disk product that is in compliance with the CompactFlash standard and True IDE mode. The M141 family CompactFlash card is in low profile form factor and fits in any systems with CF slots.

The M141 family uses superior quality preselected multi-level cell (MLC) NAND flash memory from the industry leading manufacturer Kioxia (Toshiba).

The M141 family offers outstanding performance and reliability; the product family is a perfect solution for price sensitive semi-industrial and general industrial applications.

1.2 Feature

- Compliant with ATA command set
- MLC NAND flash memory
- Capacity: 8GB ~ 64GB
- Operating as boot disk
- Static and dynamic wear leveling
- Bad block management
- S.M.A.R.T.

1.3 Product Appearance & Models

Cervoz Industrial CompactFlash Card M141



M141 Family Standard Temp. (0°C ~ 70°C) Model No.	M141 Family Wide Temp. (-40°C ~ 85°C) Model No.	Capacity
CIM-CFM141TIC008GS	CIM-CFM141TIC008GW	8GB
CIM-CFM141TIC016GS	CIM-CFM141TIC016GW	16GB
CIM-CFM141TIC032GS	CIM-CFM141TIC032GW	32GB
CIM-CFM141TKC064GS	CIM-CFM141TKC064GW	64GB

Please Note:

Since certain storage capacity has to be reserved for firmware and controller management purposes; the physical capacity of the PATA flash module will be approximately 87%~90% of the indicated capacity. If you need to install an image that has the exact (or close to) the indicated size of the flash module, please choose your flash module with a greater capacity.

2. Product Specifications

2.1 General Specifications

Form Factor	CompactFlash
Interface	CompactFlash Specification v6.0 (backward compatible to v3.x, 4.x, 5.x)
Connector	PATA (50 pin)
NAND Flash Type	MLC
Capacity	8GB/16GB/32GB/64GB
Sequential Read	up to 125MB/s
Sequential Write	up to 95MB/s
ECC Scheme	up to 72bits / 1K Byte
MTBF	>3,000,000 hours
TeraByte Written (TBW)	8GB : 8 16GB : 16 32GB : 31 64GB : 63
Low Power Management	Power Sleep mode
Supply Voltage	3.3V DC and 5V DC +/-5%
Power Consumption	Active mode: < 730mW Idle mode: < 25mW
Dimension (LxWxH)	42.8*36.4*3.3mm

2.2 Electronic Specifications

2.2.1 Block Diagram

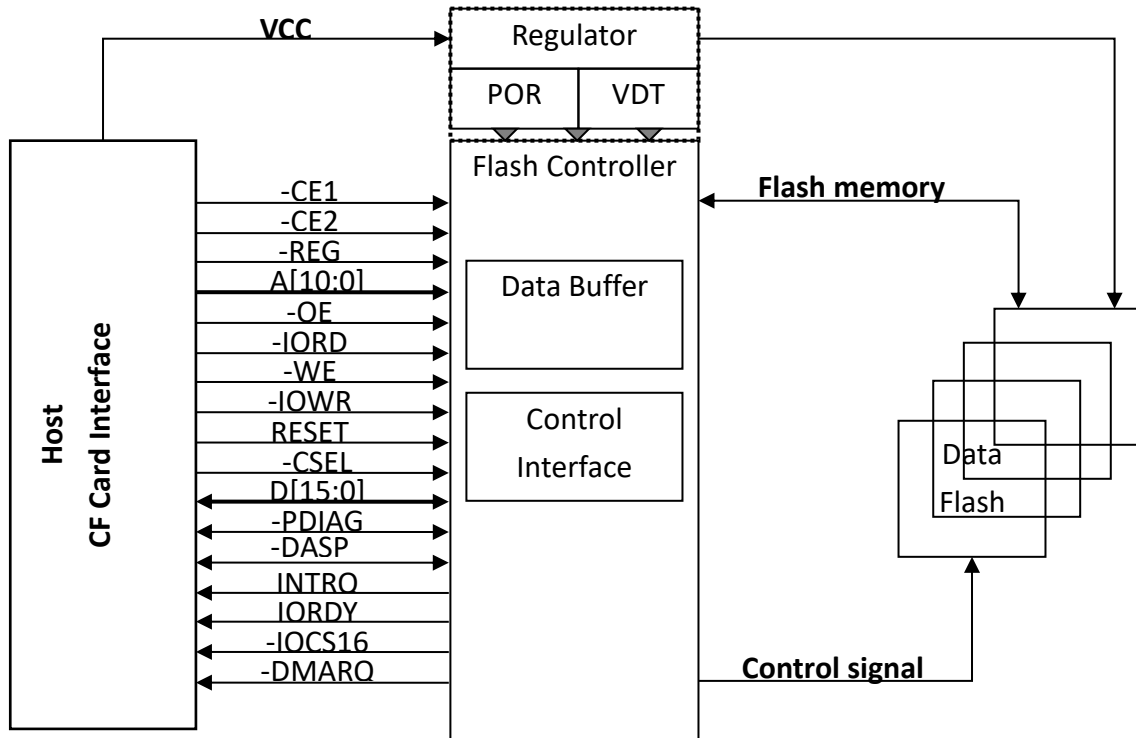

2.2.2 Pin Assignment

PC Card Memory Mode			PC Card I/O Mode			True IDE Mode		
Pin #	Signal Name	Pin Type	Pin #	Signal Name	Pin Type	Pin #	Signal Name	Pin Type
1	GND		1	GND		1	GND	I/O
2	D03	I/O	2	D03	I/O	2	D03	I/O
3	D04	I/O	3	D04	I/O	3	D04	I/O
4	D05	I/O	4	D05	I/O	4	D05	I/O
5	D06	I/O	5	D06	I/O	5	D06	I/O
6	D07	I/O	6	D07	I/O	6	D07	I
7	-CE1	I	7	-CE1	I	7	-CSO	I
8	A10	I	8	A10	I	8	A10	I
9	-OE	I	9	-OE	I	9	-ATA SEL	I
10	A09	I	10	A09	I	10	A09	I
11	A08	I	11	A08	I	11	A08	I
12	A07	I	12	A07	I	12	A07	
13	VCC		13	VCC		13	VCC	I
14	A06	I	14	A06	I	14	A06	I
15	A05	I	15	A05	I	15	A05	I
16	A04	I	16	A04	I	16	A04	I
17	A03	I	17	A03	I	17	A03	I
18	A02	I	18	A02	I	18	A02	I
19	A01	I	19	A01	I	19	A01	I
20	A00	I	20	A00	I	20	A00	I/O
21	D00	I/O	21	D00	I/O	21	D00	I/O
22	D01	I/O	22	D01	I/O	22	D01	I/O
23	D02	I/O	23	D02	I/O	23	D02	O
24	WP	O	24	-IOIS16	O	24	-IOIS16	O
25	-CD2	O	25	-CD2	O	25	-CD2	O
26	-CD1	O	26	-CD1	O	26	-CD1	I/O
27	D11	I/O	27	D11	I/O	27	D11	I/O
28	D12	I/O	28	D12	I/O	28	D12	I/O
29	D13	I/O	29	D13	I/O	29	D13	I/O
30	D14	I/O	30	D14	I/O	30	D14	I/O
31	D15	I/O	31	D15	I/O	31	D15	I

PC Card Memory Mode			PC Card I/O Mode			True IDE Mode		
Pin #	Signal Name	Pin Type	Pin #	Signal Name	Pin Type	Pin #	Signal Name	Pin Type
32	-CE2	I	32	-CE2	I	32	-CS1	O
33	-VS1	O	33	-VS1	O	33	-VS1	I
34	-IORD	I	34	-IORD	I	34	-IORD	I
35	-IOWR	I	35	-IOWR	I	35	-IOWR	I
36	-WE	I	36	-WE	I	36	-WE	I
37	RDY/BSY	O	37	IREQ	O	37	INTRQ	
38	VCC		38	VCC		38	VCC	I
39	-CSEL	I	39	-CSEL	I	39	-CSEL	I
40	-VS2	O	40	-VS2	O	40	-VS2	I
41	RESET	I	41	RESET	I	41	RESET	O
42	-WAIT	O	42	-WAIT	O	42	IORDY	O
43	-INPACK	O	43	-INPACK	O	43	-INPACK	I
44	-REG	I	44	-REG	I	44	-REG	I/O
45	BVD2	I/O	45	-SPKR	I/O	45	-DASP	I/O
46	BVD1	I/O	46	-STSCHG	I/O	46	-PDIAG	I/O
47	D08	I/O	47	D08	I/O	47	D08	I/O
48	D09	I/O	48	D09	I/O	48	D09	I/O
49	D10	I/O	49	D10	I/O	49	D10	
50	GND		50	GND		50	GND	

NOTES:

1. WE should be connected to VCC in True IDE mode.
2. CSEL is the input pin for master/slave selection used in True IDE mode.

2.3 Environmental Specifications

Type		Value
Temperature	Standard Temperature Operating:	0°C~70°C
	Standard Temperature Storage:	-40°C~85°C
	Wide Temperature Operating:	-40°C~85°C
	Wide Temperature Storage:	-50°C~95°C
Humidity	Operating & Storage	10~95%, Non-Condensing
Vibration	Non-Operating	20G, 10Hz~2000Hz
Shock	Non-Operating	1500G, 0.5ms

2.4 Mechanical Specifications

Type	Value
Form Factor	CompactFlash
Length	42.80mm +/-0.10mm
Width	36.40mm +/-0.15mm
Thickness	3.30mm +/-0.10mm

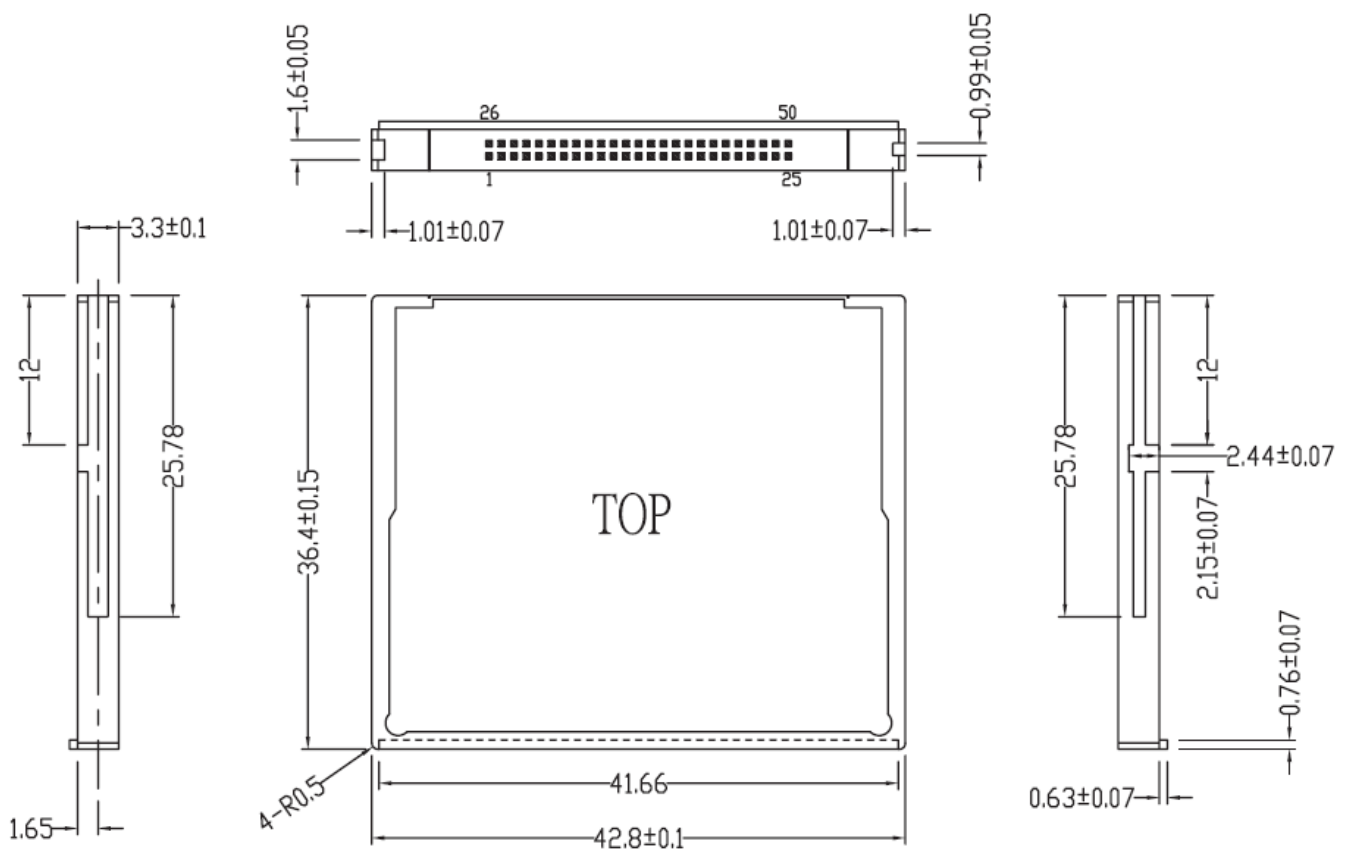

3. Supported Command

3.1 Identify Drive Information

Word Address	Default Value	Total Bytes	Data Field Type Information
0	848AH	2	General configuration bit-significant information
1	XXXX	2	Default number of cylinders
2	0000H	2	Reserved
3	XXXX	2	Default number of heads
4	0000H	2	Retired
5	0200H	2	Retired
6	XXXX	2	Default number of sectors per track
7-8	XXXXh	4	Number of sectors per card
9	0000H	2	Retired
10-19	XXXX	20	Serial Number in ASCII
20	0002H	2	Retired
21	0002H	2	Retired
22	0004H	2	Obsolete
23-26	XXXX	8	Firmware revision in ASCII
27-46	XXXX	40	Model number in ASCII
47	0001H	2	Maximum number of sector that shall be transferred on Read/Write Multiple commands
48	0000H	2	Reserved
49	0300H	2	Obsolete
50	0000H	2	Reserved
51	0200H	2	PIO data transfer cycle timing mode 2
52	0000H	2	Retired
53	0007H	2	Word 54-58, 64-70 and 88 are valid
54	XXXX	2	Current numbers of cylinders
55	XXXX	2	Current numbers of heads
56	XXXX	2	Current sectors per track
57-58	XXXX	4	Current capacity in sectors (LBAs)(Word 57= LSW, Word 58= MSW)
59	0101H	2	Multiple sector setting is valid
60-61	XXXX	4	Total number of sectors addressable in LBA Mode

Word Address	Default Value	Total Bytes	Data Field Type Information
62	0000H	2	Retired
63	0007H	2	Multiword DMA mode 2 and below are supported
64	0003H	2	Advance PIO transfer modes supported
65	0078H	2	Minimum Multiword DMA transfer cycle time 120nsec
66	0078H	2	Manufacturer's recommended Multiword DMA transfer cycle time 120nsec
67	0078H	2	Minimum PIO transfer cycle time without flow control 120nsec
68	0078H	2	Minimum PIO transfer cycle time with IORDY flow control 120nsec
69-81	0000H	26	Reserved
82	0002H	2	Supports Security Mode feature set
83-87	0000H	10	Reserved
88	0X3FH	2	Ultra DMA mode 5 and below are supported
89-127	0000H	78	Reserved
128	0021H	2	Enhanced security erase supported
129-159	0000H	62	Reserved vendor unique bytes
160-255	0000H	192	Reserved

4. Part No. Decoder

4.1 Part No. Decoder

1	-	2	3	4	5	6	7	8	9
Product Line	-	Form Factor	Product Series	Cervoz Family Code (Bus / Internal Control)	NAND Flash	Flash Capacity	Flash Mode	Module Capacity	Operating Temp.
XXX	-	XX	X	XXX	X	X	X	XXXX	X

1. Product Line

CIS	Cervoz Industrial SSD
CIM	Cervoz Industrial Memory Card
CIE	Cervoz Industrial Embedded Module

2. Form Factor

2S	2.5" SATA
2P	2.5" PATA
CF	CompactFlash
CA	CFast
MS	mSATA
HM	Half Size mSATA
HS	Half Slim
M4	M.2 2242
M6	M.2 2260
M8	M.2 2280
0V	PATA Disk 40pin Vertical
4V	PATA Disk 44pin Vertical
4L	PATA Disk 44pin Horizontal Left
7T	SATA Disk 7pin Vertical Tall
7L	SATA Disk 7pin Horizontal Left
7R	SATA Disk 7pin Horizontal Right

3. Product Series

S	Supreme Series (SLC)
R	Reliance Series (RO-MLC)
M	Momentum Series (MLC)

4. Cervoz Family Code

Bus and Internal Control for Cervoz Product Families

5. NAND Flash

M	Micron
T	Toshiba

6. Flash Capacity

A	256Mb
B	512Mb

C	1Gb
D	2Gb
E	4Gb
F	8Gb
G	16Gb
H	32Gb
I	64Gb
J	128Gb
K	256Gb
L	512Gb
M	1Tb

7. Flash Mode

Internal Control for Flash Mode

8. Module Capacity

128M	128MB
256M	256MB
512M	512MB
001G	1GB
002G	2GB
004G	4GB
008G	8GB
016G	16GB
032G	32GB
064G	64GB
128G	128GB
256G	256GB
512G	512GB

9. Operating Temperature

S	Standard Grade (0~ +70°C)
W	Wide Temperature Grade (-40 ~ +85°C)